

RoHS

REV.	DESCRIPTION	DATE	DWG.	CHKD
0	PROPOSED	13/08/07	B.K	T.H

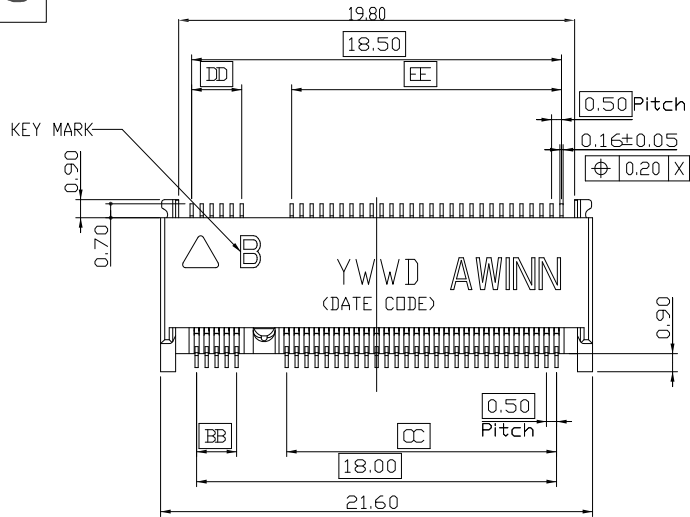

TABLE 1:

KEY #	AA	BB	CC	DD	EE
A	+6.625	1.0	14.5	1.5	14.5
B	+5.625	2.0	13.5	2.5	13.5
E	+2.625	5.0	10.5	5.5	10.5
M	-6.125	14.0	1.5	14.0	2.0

ITEM	PART NAME	Q'TY	MATERIAL	FINISH
1	BODY	1	LCP	
2	UPPER CONTACT	34	PHOSPHOR BRONZE	GOLD PLATING
3	UPPER CONTACT	33	PHOSPHOR BRONZE	GOLD PLATING
4	HOLD DOWN	2	BRASS	TIN 100u"

TABLE 2:

SERIES NUMBER	H	H1	H2
AWM-215	2.10	2.15	0.60

DESIGNATION
 AWM-XXXXXXR
 AWM: SERIES NUMBER XXX
 X: KEY CODE (A, B, E, M)
 XX: PLATING CODE FOR CONTACT AREA
 01:G/F
 03:3u"
 10:10u"
 15:15u"
 30:30U"
 R: PACKING FOR TAPE& REEL

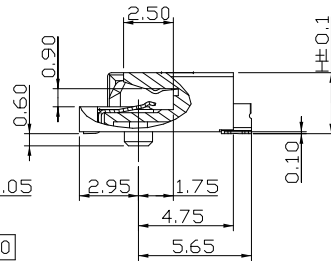
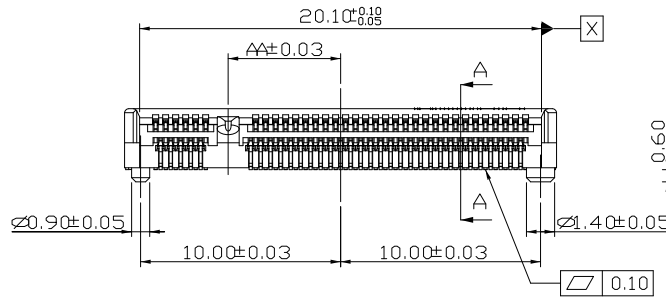

SECTION A-A

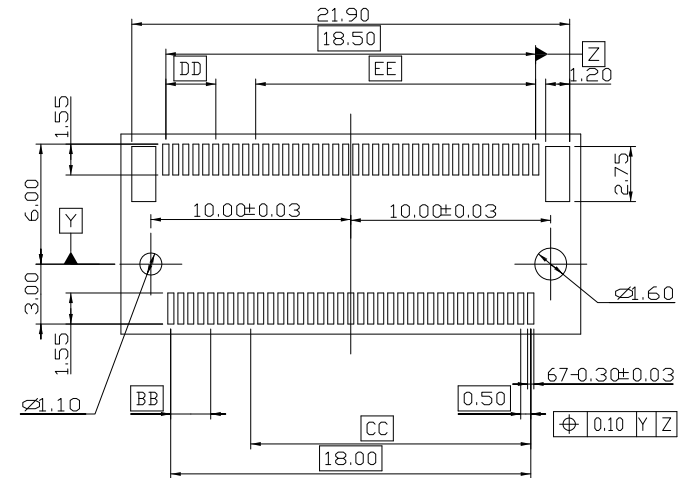

RECOMMEND NGFF MINI CARD MOUNTING TYPE_SMT_PCB OUTLIN :
 GENERAL TOLERANCE ±0.05mm



MATING CONDITION SCALE: 2:1

FINISH		NAME		PART NO.	
MATERIAL	*****	NET WEIGHT	COLOR	GENERAL TOLERANCE	UNIT:mm
FIN. & TREAT	*****	GROSS WEIGHT	SCALE	±0.2 ±3°	⊗
CUSTOMER	*****	PART NO.	MAWM-215E01R	SIZE	A3
CUSTOMER PART NO.	*****	PROPOSAL NO.		REV.	○
美星鴻科技股份有限公司 MSH TECHNOLOGY INC.		NAME	NGFF CONNECTOR	REV.	*
APP.	'13/08/07	CHKD	'13/08/07	DWG.	'13/08/07
T.HASHIMOTO	T.HASHIMOTO	B.KA			

REV.	DESCRIPTION	DATE	DWG.	CHKD
0	PROPOSED	13/08/07	B.K	T.H

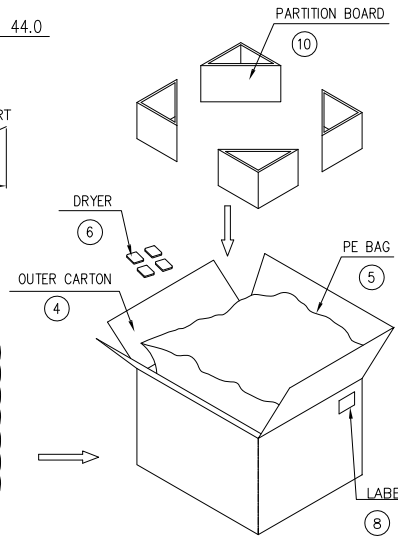
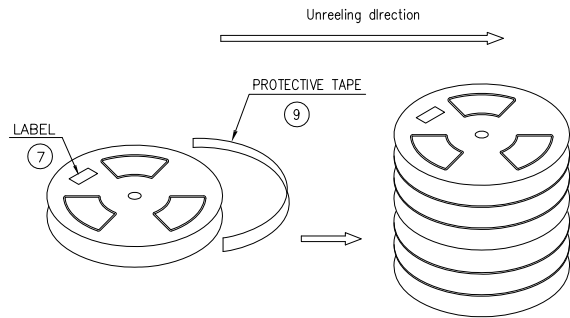
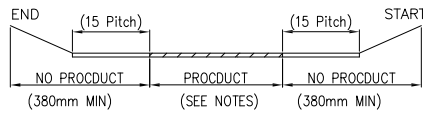
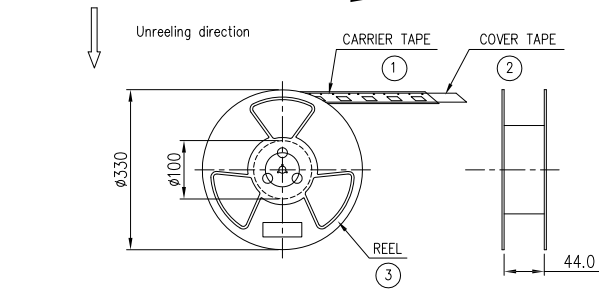
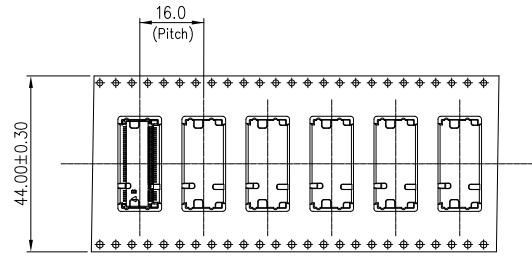

NOTES:

- PACKING STYLE A) AWN215XXXR (2.15H)
1200 PCS/REEL
7200 PCS/OUTER CARTON
B) AWN310XXXR (3.1H)
900 PCS/REEL
5400 PCS/OUTER CARTON
C) AWN410XXXR (4.1H)
750 PCS/REEL
4500 PCS/OUTER CARTON
- MATERIAL CARRIER TAPE: PS BLACK
COVER TAPE: PET FILM
REEL: PLASTIC
- PEEL STRENGTH OF COVER TAPE: 20-80g (PEEL SPEED 300mm/MINUTE).

10	PARTITION BOARD	53WP032A0010	4	PCS	
9	PROTECTIVE TAPE	53WB071B0011	6	PCS	
8	LABEL	53WG020A0011	1	PCS	
7	LABEL	53WG010A0011	6	PCS	
6	DRYER	53WD010A0011	4	BAG	
5	PE BAG	53WB082A0021	1	PCS	W750*L850*0.06m
4	OUTER CARTON	53WP022A0060	1	PCS	350*350*320mm
3	REEL	53WB041B0011	6	SET	φ330*100mm, W=4
2	COVER TAPE	53WB061B1011	SEE NOTES 6	PCS	W=37.5mm
1	CARRIER TAPE	53WB051B0080			W=44mm, T=0.4mm
NO.	PACKING NAME	PART NO.	PCS/R/R/BOX	UNIT	NOTE
			PACKING QTY		

FINISH		NAME		PART NO.	
MATERIAL	NET WEIGHT	COLOR	GENERAL TOLERANCE	UNIT: mm	
*****			±0.2 ±3°	A3	
FIN. & TREAT	GROSS WEIGHT	SCALE	SIZE	REV. ○	
*****				REV. *	
CUSTOMER	PART NO.		MAWM-215E01R		
CUSTOMER PART NO.	PROPOSAL NO.				
*****	NAME		NGFF CONNECTOR		
APP. '13/08/07		CHKD '13/08/07	DRG. '13/08/07	SHEET 2 OF 2	
T.HASHIMOTO		T.HASHIMOTO	B.KA		

美星鴻科技股份有限公司
MSH TECHNOLOGY INC.